

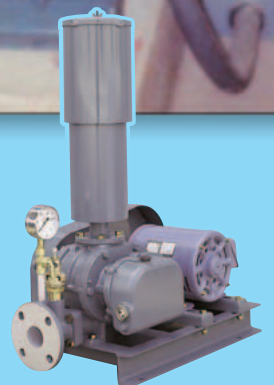

# *Rotary Air Blowers*

## **RS (S, A, R)**



**Amenics**  
Amenities from Technology  
for People and the Earth

**Horizontal type** — Works as it should for a wide variety of applications.

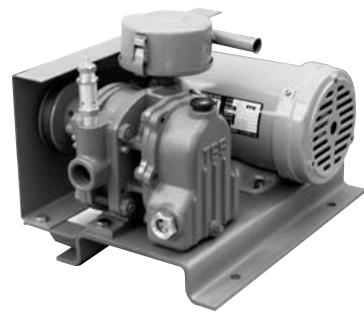

**RSS**  
(Discharge Bore 20, 25, 32mm)

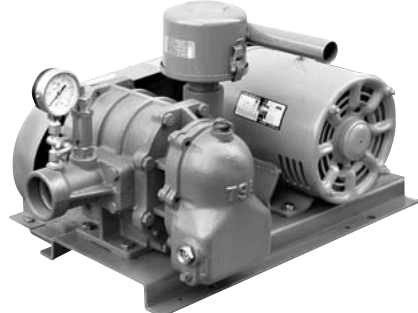

**RSA**  
(Discharge Bore 40, 50, 65mm)



**RSR**  
(Discharge Bore 50, 65, 80, 100, 125, 150mm)

### Applications

- Aeration at water treatment facilities;
- Stirring of various waste liquids and sewage to prevent putrefaction and scum;
- Oxygen supply at aquariums and fish farms.

### Virtues

- The rush of suction or discharge has been tamed resulting in greatly reduced impact noise and pulsation noise.
- Minimized operation noise, even and stable performance plus outstanding durability.
- Compact design for space economy and effortless maintenance services.

### Structural Features

#### Innovative helical intake / outlet

Conventional blowers were designed to discharge the air from the casing in a gust. This caused violent impact and pulsation and resultant noise. Tsurumi blowers have helical structure at the intake and the outlet. This makes the air virtually pass through a gradually closing suction port or gradually opening discharge port. The result is remarkably reduced pulsation noise.

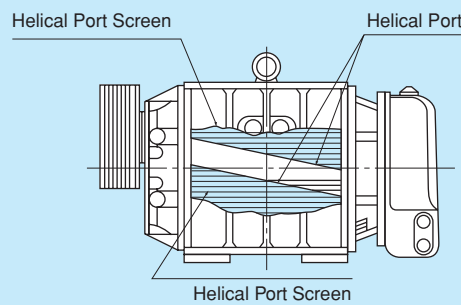

#### Special silencer and 3-lobe rotor

A specially prepared silencer absorbs a broad range of noise frequencies from low to high. The air flow rate and pressure characteristics have been greatly upgraded by the adoption of a 3-lobe rotor with each blade deliberately displaced as to thrust direction to avoid mutual contact.



#### Helical Port

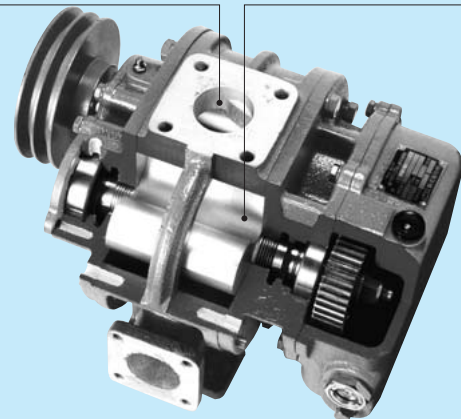
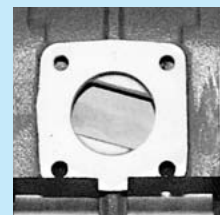

#### Rotor

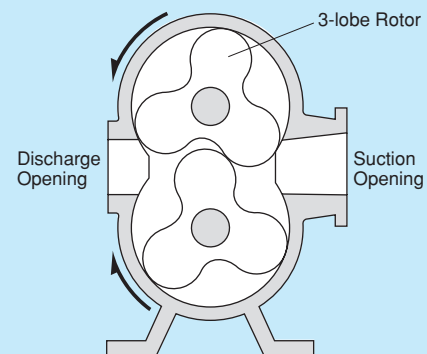

### Major Standard Specifications

Item	Discharge bore (mm)											
	20	25	32	40	50	65	80	100	125	150		
Treating fluid	Type of fluid	Air										
	Fluid temperature	0~40°C										
Blower	Structure	Rotor	3-lobe rotor									
		Shaft seal	Labyrinth									
		Bearing	Shielded ball bearing									
	Materials	Rotor	Gray iron casting									
		Casing	Gray iron casting									
Shaft	Carbon steel											
Motor	Type, Pole	Drip-proof motor, 4-pole										
	Class of insulation	Class E										
	Phase	Single-phase (0.4kW only) Three-phase										
Discharge connection		RSS & RSA / Screw (ISO Rc-type) RSR / JIS 10K flange										

### Standard Accessories

- Common base.....1 pc.
- Suction silencer (with air filter).....1 set
- Safety valve.....1 set
- Pressure gauge (RSA, RSR).....1 set
- Foundation bolts.....1 set

### Optional Accessories

- Discharge silencer
- Flexible joint
- Gate valve
- Check valve
- Rubber vibration isolator (with vibration-isolating base)
- Totally-enclosed, outdoor motor

### Reference Drawing for Piping (Example)

#### RSS · RSA

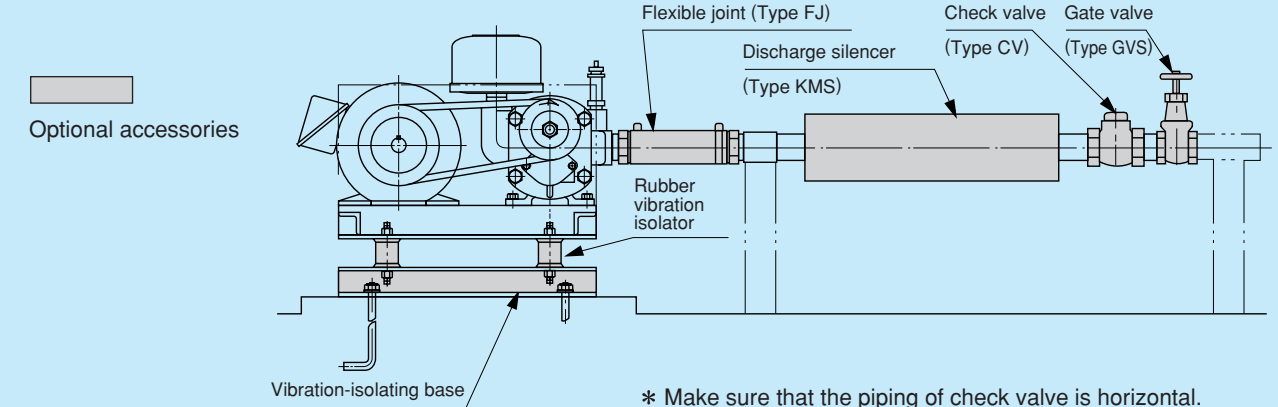

\* Make sure that the piping of check valve is horizontal.

## HOW TO USE THE PERFORMANCE TABLE

### Information about 50/60Hz Standard Specification Tables

These tables indicate the relationships among blower models, bores, rpm, discharge pressure, actual air flow rates, and shaft power.

1. The amounts of air indicated in the tables represent suction amounts under the following standard suction conditions: temperature, 20 ; absolute pressure, 101.3kPa {1.033kgf / cm<sup>2</sup>}, relative humidity, 65%.
2. The amounts of air under reference suction conditions (temperature, 0 ; absolute pressure, 101.3kPa {1.033kgf / cm<sup>2</sup>}) can be converted into the amounts of air under the standard suction conditions by the formula below if the suction pressures are the same:

$$Q_s = Q_n \times \frac{273 + t_s}{273}$$

where

Q<sub>s</sub>, amount of air (m<sup>3</sup> / min) under standard suction conditions indicated on Standard Specification Tables;  
Q<sub>n</sub>, amount of air (m<sup>3</sup> / min) under reference suction conditions;  
Suction pressure is ambient pressure, 101.3kPa; t<sub>s</sub>, suction temperature in .

3. To convert the amounts of air under discharge conditions into the amounts of air under the standard suction conditions indicated on the Standard Specification Tables, use the following formula:

$$Q_s = Q_d \times \frac{101.3 + P_d}{101.3} \times \frac{273 + t_s}{273 + t_d}$$

where

Q<sub>d</sub>, amount of air (m<sup>3</sup> / min) under discharge conditions;  
P<sub>d</sub>, discharge pressure (kPa);  
t<sub>s</sub>, suction temperature in ;  
t<sub>d</sub>, discharge temperature in .

4. Using the amount of air and the necessary discharge pressure obtained from the above mathematics, determine your blower model, bore, rpm, and shaft power in reference to a Standard Specification Table.
5. Your selectable range can be overlapped over several models. It is recommended that the one with a younger model number for cost economy, or with a larger model number for lower noise, be selected.
6. Motor output is identified by color on the Standard Specification Tables. Select a suitable color motor from these tables.

# RSS SERIES

## Standard specifications 50/60Hz

Model (Discharge bore mm)	Revolutions (min <sup>-1</sup> )	Suction air volume at 20 (Qs, m <sup>3</sup> /min) and required power (La, kW)									
		9.8kPa {0.1kgf/cm <sup>2</sup> }		19.6kPa {0.2kgf/cm <sup>2</sup> }		29.4kPa {0.3kgf/cm <sup>2</sup> }		39.2kPa {0.4kgf/cm <sup>2</sup> }		49.0kPa {0.5kgf/cm <sup>2</sup> }	
		Qs	La	Qs	La	Qs	La	Qs	La	Qs	La
RSS-20 (20)	1750	0.16	0.20	0.14	0.24	0.12	0.28	0.10	0.32	-	-
	2000	0.20	0.23	0.18	0.27	0.16	0.31	0.14	0.35	-	-
	2250	0.24	0.26	0.22	0.31	0.20	0.35	0.18	0.40	0.16	0.46
	2500	0.27	0.29	0.25	0.34	0.23	0.39	0.21	0.44	0.19	0.50
Corresponding motor output		0.4kW				0.75kW					
RSS-25 (25)	1750	0.21	0.23	0.18	0.27	0.15	0.32	-	-	-	-
	2000	0.27	0.26	0.24	0.31	0.21	0.37	0.18	0.43	-	-
	2250	0.31	0.30	0.28	0.35	0.25	0.42	0.22	0.49	-	-
	2500	0.36	0.33	0.33	0.39	0.30	0.46	0.27	0.54	0.23	0.62
Corresponding motor output		0.4kW				0.75kW					
RSS-32 (32)	1750	0.36	0.27	0.32	0.34	0.28	0.42	0.24	0.50	-	-
	2000	0.44	0.31	0.40	0.39	0.36	0.48	0.32	0.57	-	-
	2250	0.52	0.35	0.48	0.44	0.44	0.54	0.40	0.64	-	-
	2500	0.60	0.39	0.56	0.49	0.52	0.60	0.48	0.71	0.42	0.86
Corresponding motor output		0.4kW				0.75kW				1.5kW	

## Performance curves

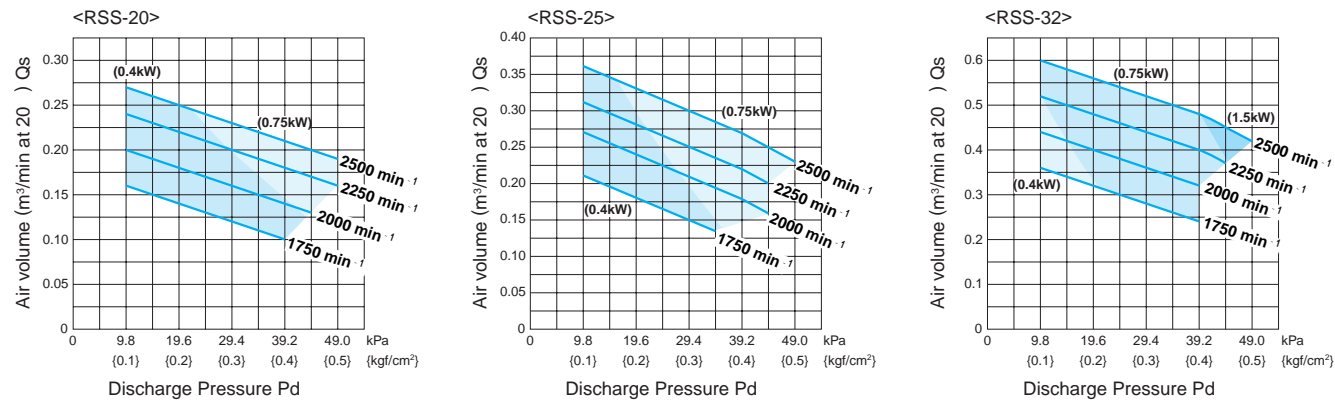

## Noise level (1.0m on machine side)

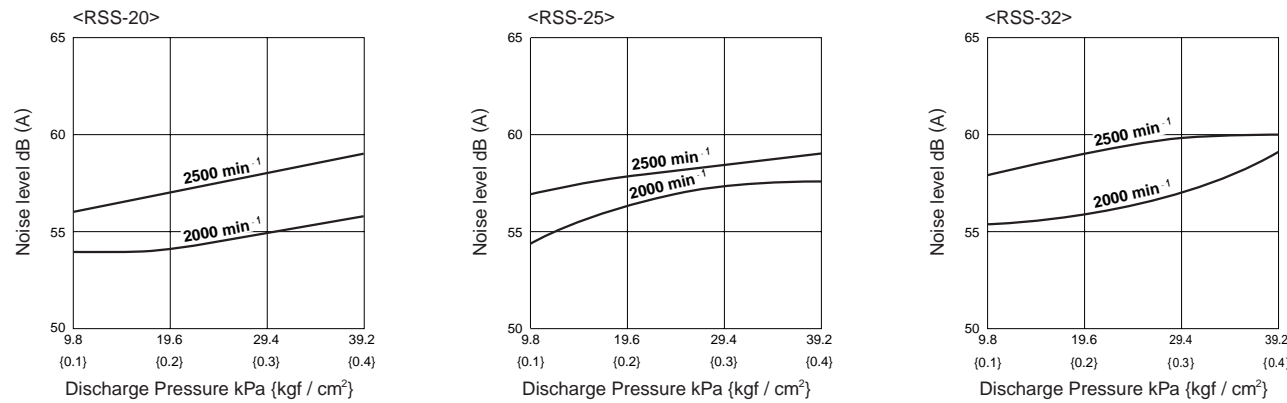

## Dimensions Unit : mm

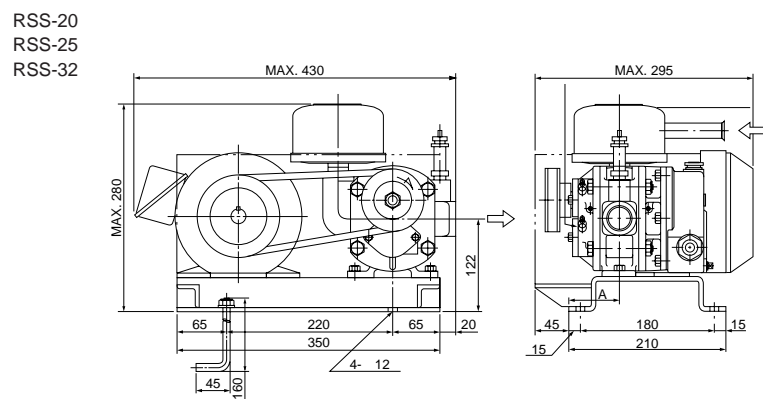

## Table of dimensions Unit : mm

Model	A	Weight kgs
RSS-20	60	19
RSS-25	67	20
RSS-32	80	22

Weight of blower itself not including motor. Please see the motor weight table for motor weight including standard accessories.

## Motor weight table Unit : kgs

Motor output (kW)	0.4	0.75
Drip-proof (single-phase)	7	-
Drip-proof (three-phase)	-	10
Totally-enclosed (three-phase)	8	12

# RSA SERIES

## Standard specifications 50/60Hz

Model (Discharge bore mm)	Revolutions (min <sup>-1</sup> )	Suction air volume at 20 (Qs, m <sup>3</sup> /min) and required power (La, kW)									
		9.8kPa {0.1kgf/cm <sup>2</sup> }		19.6kPa {0.2kgf/cm <sup>2</sup> }		29.4kPa {0.3kgf/cm <sup>2</sup> }		39.2kPa {0.4kgf/cm <sup>2</sup> }		49.0kPa {0.5kgf/cm <sup>2</sup> }	
		Qs	La	Qs	La	Qs	La	Qs	La	Qs	La
RSA-40 (40)	1000	0.45	0.32	0.39	0.40	0.33	0.52	-	-	-	-
	1250	0.65	0.40	0.59	0.50	0.53	0.65	0.48	0.80	0.43	0.99
	1500	0.84	0.48	0.78	0.60	0.72	0.78	0.67	0.96	0.62	1.18
	1750	1.04	0.56	0.98	0.70	0.92	0.91	0.87	1.11	0.82	1.38
Corresponding motor output		0.75kW					1.5kW				
RSA-50 (50)	1000	0.82	0.64	0.73	0.80	0.65	1.04	0.57	1.28	-	-
	1250	1.22	0.80	1.13	1.00	1.05	1.30	0.97	1.60	0.89	1.97
	1500	1.61	0.96	1.52	1.20	1.44	1.56	1.36	1.92	1.28	2.36
	1750	2.01	1.12	1.92	1.40	1.84	1.82	1.76	2.22	1.68	2.76
Corresponding motor output		1.5kW			2.2kW			3.7kW			
RSA-65 (65)	1000	1.19	0.80	0.94	1.00	0.75	1.30	0.59	1.60	-	-
	1250	1.69	1.00	1.45	1.25	1.26	1.63	1.10	2.00	0.99	2.45
	1500	2.18	1.20	1.93	1.50	1.74	1.95	1.58	2.40	1.47	2.95
	1750	2.68	1.40	2.43	1.75	2.24	2.28	2.08	2.78	1.97	3.45
Corresponding motor output		1.5kW			2.2kW			3.7kW			

## Performance curves

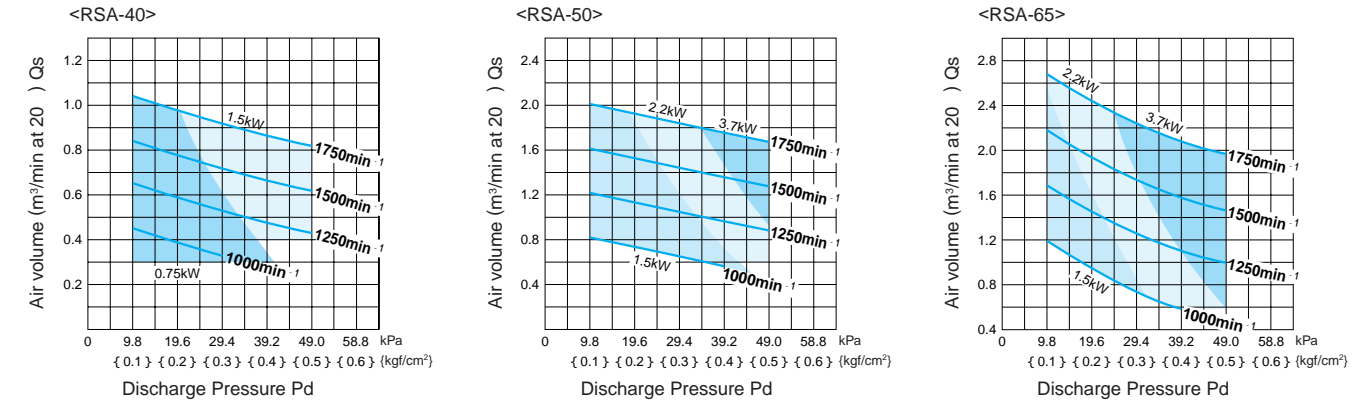

## Noise level (1.0m on machine side)

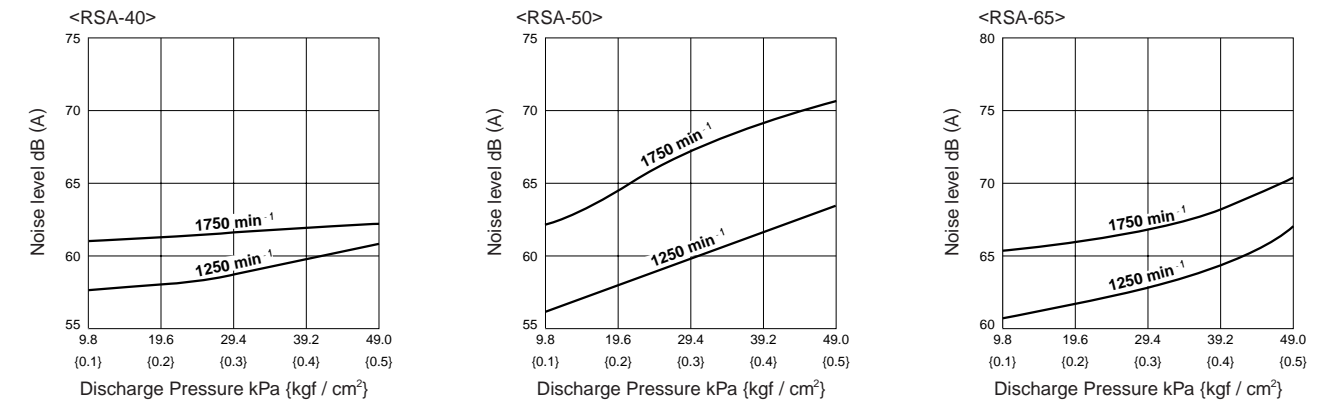

## Dimensions Unit : mm

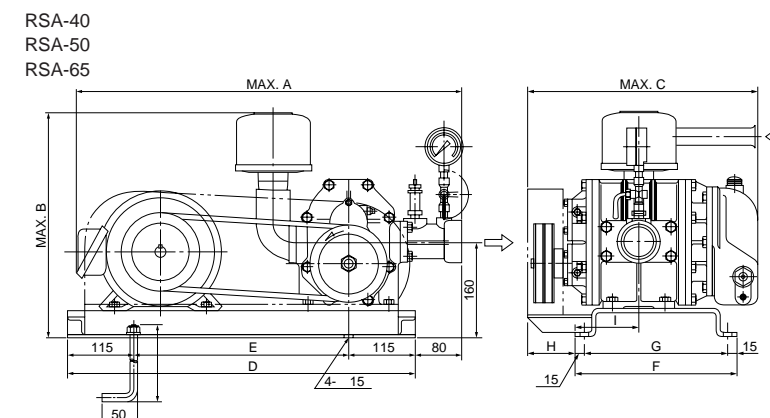

## Table of dimensions Unit : mm

Model	A	B	C	D	E	F	G	H	I	Weight kgs
RSA-40	670	360	350	550	320	250	220	60	85	42
RSA-50	700	380	405	600	370	280	250	80	110	61
RSA-65	700	380	440	600	370	280	250	80	130	64

Weight of blower itself not including motor. Please see the motor weight table for motor weight including standard accessories.

## Motor weight table Unit : kgs

Motor output (kW)	0.75	1.5	2.2	3.7
Drip-proof	10	17	22	32
Totally-enclosed	12	20	26	40



# Pumps & Other Equipment For Water Treatment

Tsurumi provides you with an extensive lineup of models to suit your specific needs.

## SEWAGE PUMP

**B** series



Discharge Bore : 50 - 800 mm  
Motor Output : 0.4 - 110 kW

## RESIN-MADE SEWAGE PUMP

**PU** series



Discharge Bore : 40 - 80 mm  
Motor Output : 0.15 - 1.5 kW

## AERATOR

**TRN** series



Air-Inlet Bore : 32 - 150 mm  
Motor Output : 0.75 - 40 kW

## EJECTOR

**BER** series



Air-Inlet Bore : 25 - 50 mm  
Motor Output : 0.75 - 5.5 kW

## FLOATING SCUM SKIMMER

**FSP** series



Discharge Bore : 50 mm  
Motor Output : 0.4 - 0.75 kW

## FLOATING DECANTER

**FHP** series



Discharge Bore : 40 - 80 mm  
Motor Output : 0.25 - 1.5 kW

We reserve the right to change the specifications and designs for improvement without prior notice.

**TSURUMI**  
MANUFACTURING CO.,LTD.

Your Dealer