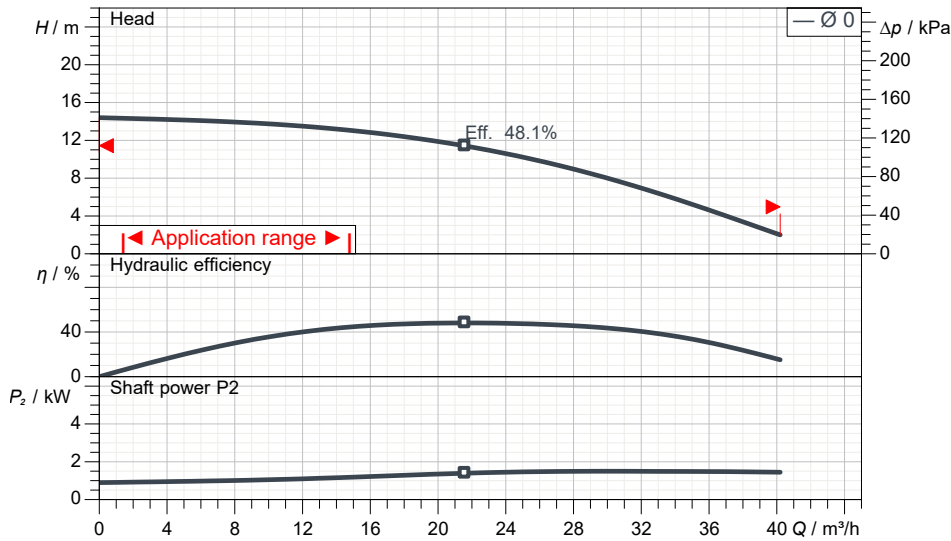

KTZ31.5-52 380-415V
Technical specification
3~ 50 Hz

Pump

Series	KTZ
Pump name	KTZ31.5-52 380-415V
Standard	

Motor data

Motor	JT1-2-1.5-KTZ 400V D UL
Rated voltage	380 V
Frequency	50 Hz
Motor phases	3~
Number of poles	2
Rated power P_2	1.50 kW

Rated current	3.6 A
rpm	2889 1/min
Rated torque	5.0 Nm
Start*	Direct starting

Degree of protection	IP 68
Insulation class	F
Protection device	
Type of oil	Turbine oil VG32
Oil amount	0.74 l

Hydraulic

Free passage	
Impeller type	Semi-open impeller
Max. hydraulic efficiency	48.1 %
Discharge	80 mm
Curve tolerance	UNI EN ISO 9906:2012

Operating limits (standard pumps)

Max. ambient temperature	40 °C
Max. density treated liquid	1030 kg/m ³
pH treated liquid	5-9
Max. start per hour (equally distributed)	6
Wet/dry use	WET
Operating mode	S1

Construction materials

Motor enclosure	Gray Iron Casting 150
Shaft	420J2 Stainless Steel
Pump Casing	Gray Iron Casting 200
Impeller	High chromium casting
Suction Cover	Ductile Iron Casting 500
Painting	
Screws	304 Stainless Steel
Gaskets	NBR

Construction features

Power cable1	4C*1.25mm ²
Power cable2	N/A
Sheath	VCT
Control cable	N/A
Sheath	N/A
Cable length	8 m
Mechanical seals	H-20T
Weight*	33 kg

* cable and fixing system excluded

Monitoring features

Monitoring option	
leaking sensor	-
monitoring equipment	-

KTZ31.5-52 380-415V
Pump performance curves
3 ~ 50 Hz

Discharge 80 mm	Head	Capacity	Rated power 1.5 kW	Voltage 380 V	Current 3.6 A	rpm 2889 1/min
---------------------------	-------------	-----------------	------------------------------	-------------------------	-------------------------	--------------------------

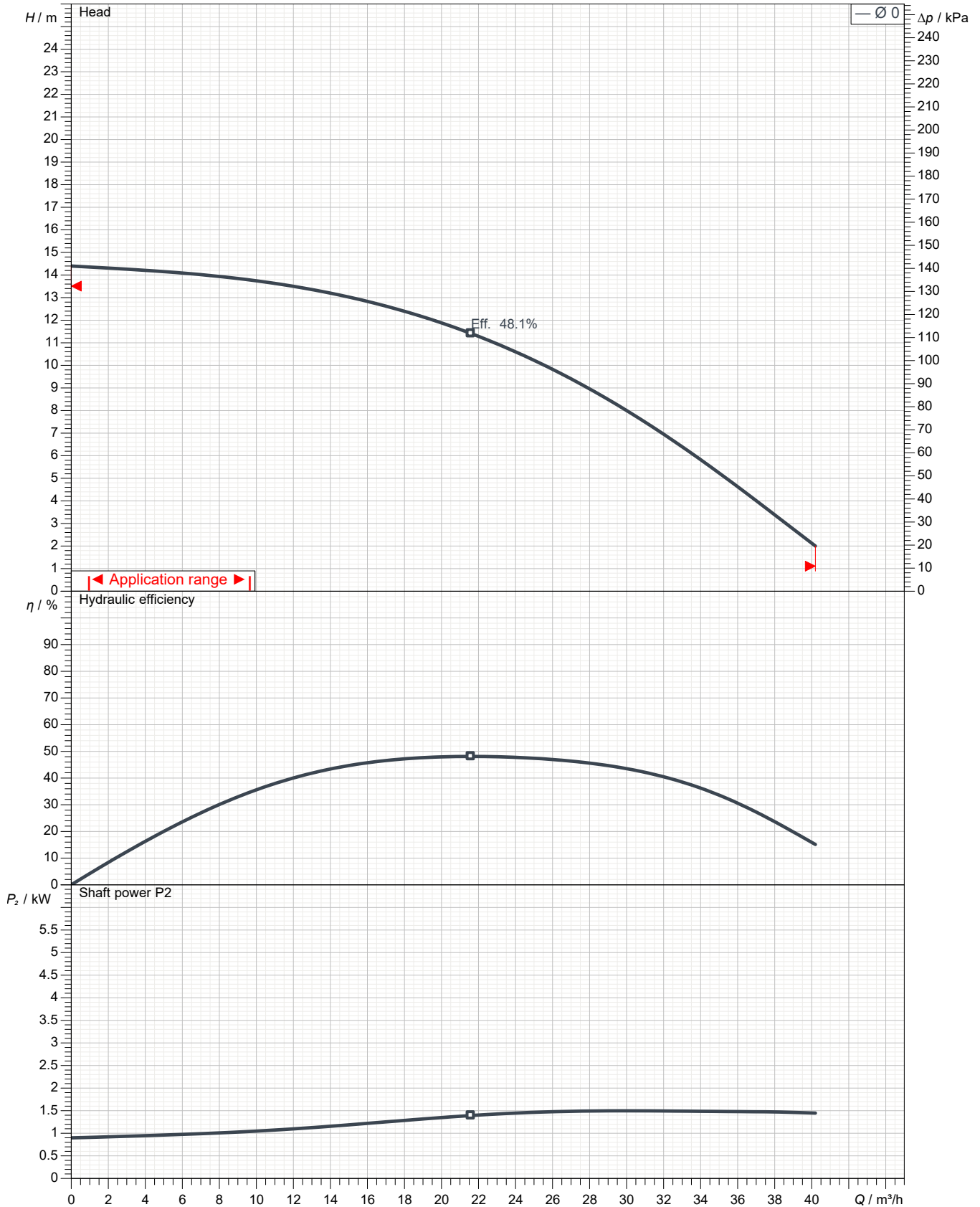

DIMENSION DRAWING		No.	No. A-28339-25Y
TYPE	Submersible Dewatering Pump	MODEL	KTZ31.5 -52

Approximate Weight(※)
33kg

※excluding cable

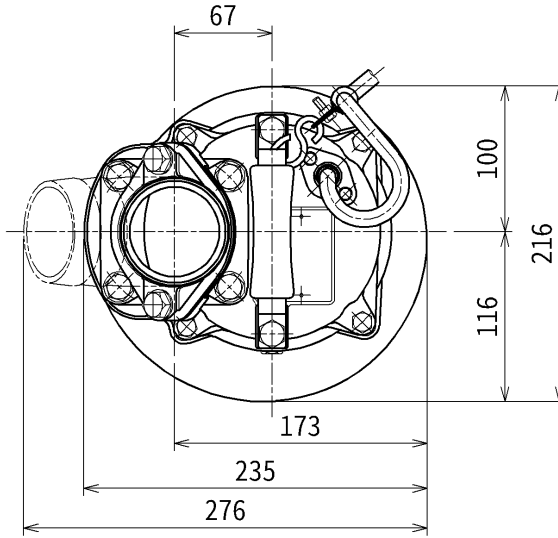

Nominal Dia.
φ 80

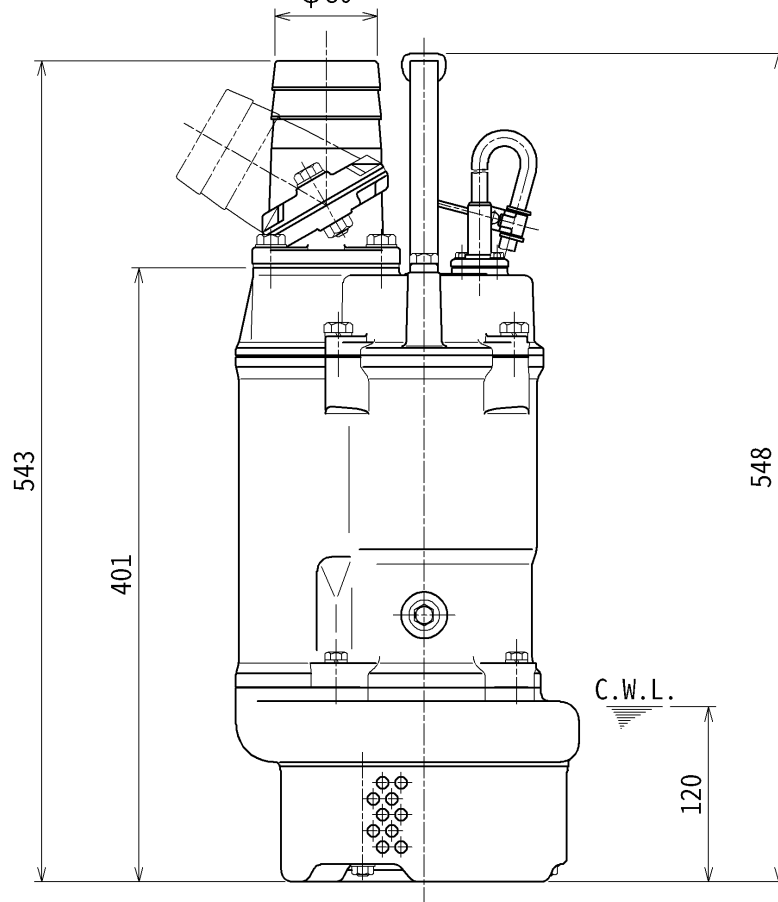

C.W.L.:Continuous running Water Level

SECTIONAL DRAWING		No.	No. A-28341-35Y
TYPE	Submersible Dewatering Pump	MODEL	KTZ31.5 -52

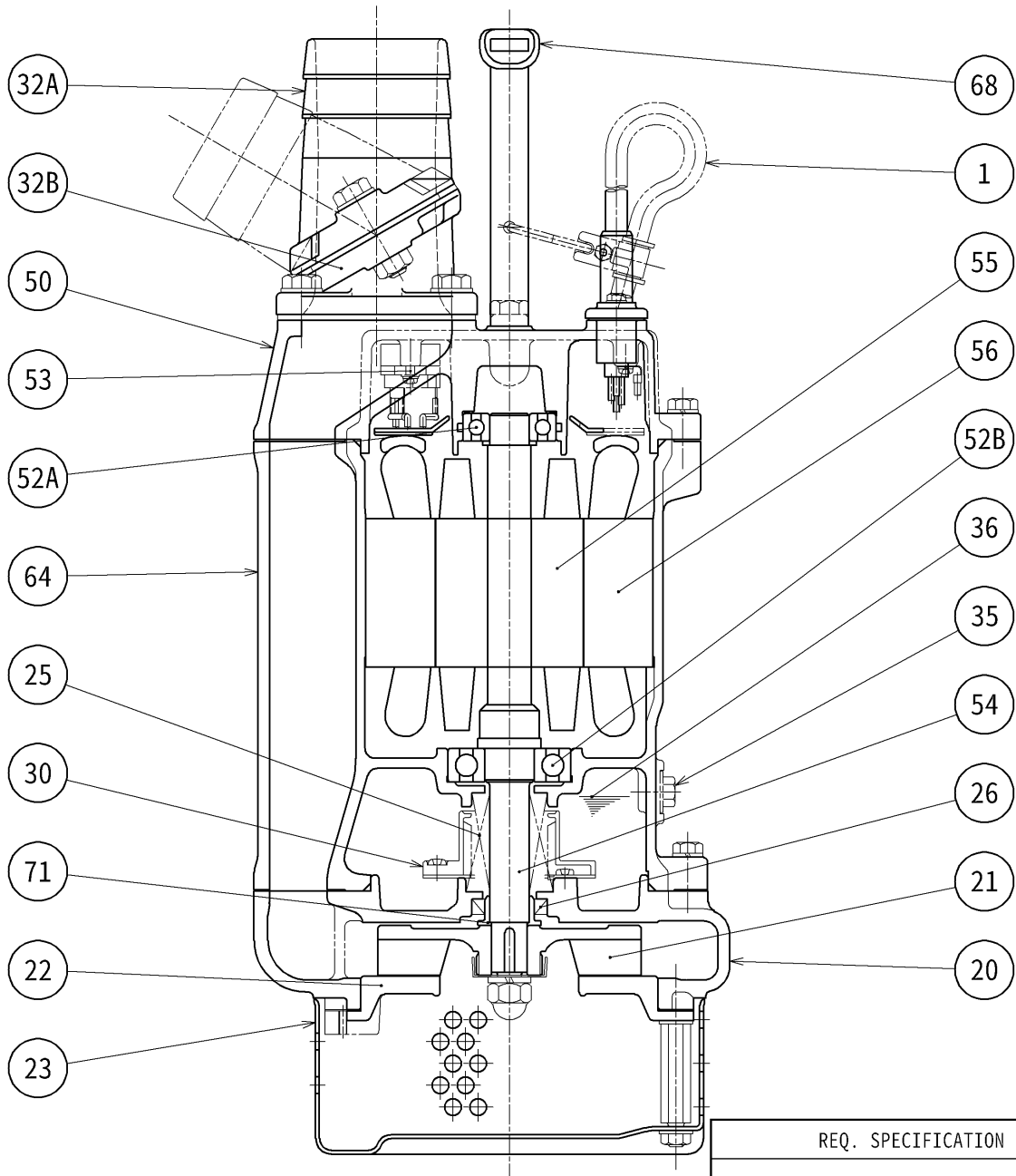

REQ. SPECIFICATION

No.	DESCRIPTION	Q'TY	MATERIAL / NOTE	No.	DESCRIPTION	Q'TY	MATERIAL / NOTE
1	Cabtyre Cable	1	PVC Sheath	50	Motor Bracket	1	Gray Iron Casting 150
20	Pump Casing	1	Gray Iron Casting 200	52A	Upper Bearing	1	6204ZZC3
21	Impeller	1	Chromium Iron Casting	52B	Lower Bearing	1	6305ZZC3
22	Suction Cover	1	Ductile Iron Casting 500	53	Motor Protector	1	
23	Strainer Stand	1	Steel Sheet	54	Shaft	1	420J2 Stainless Steel
25	Mechanical Seal	1	H-20T	55	Rotor	1	
26	Oil Seal	1	TC25388	56	Stator	1	
30	Oil Lifter	1	Plastic	64	Motor Frame	1	Gray Iron Casting 150
32A	Hose Coupling	1	Aluminium Die Casting 12	68	Handle	1	Stainless Steel & Nitrile Butadiene Rubber
32B	Hose Coupling Attachment	1	Aluminium Die Casting 12	71	Shaft Sleeve	1	304 Stainless Steel
35	Oil Plug	1	304 Stainless Steel				
36	Lubricant		Turbine Oil(ISO VG32)				